

4.2. Regime Urbanístico - Edificações

4.2.1. Alinhamento Viário

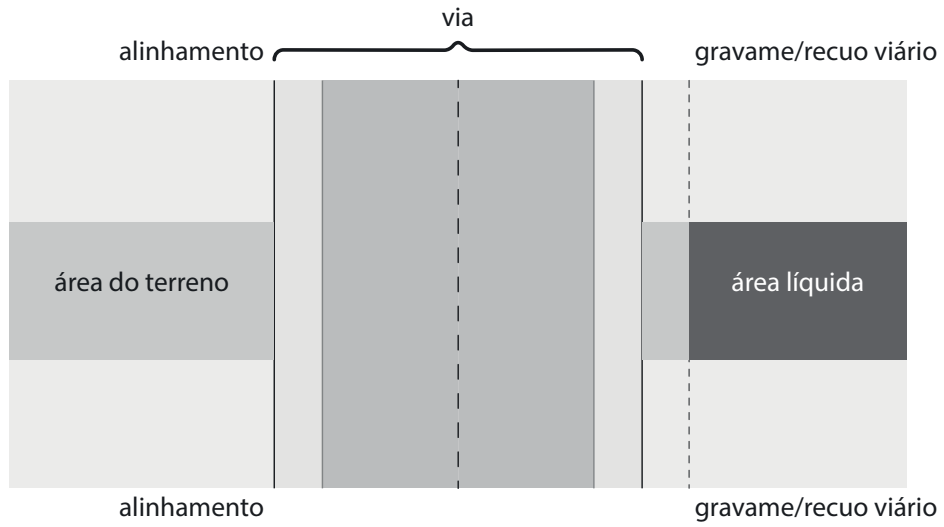

4.2.2. Taxa de Ocupação

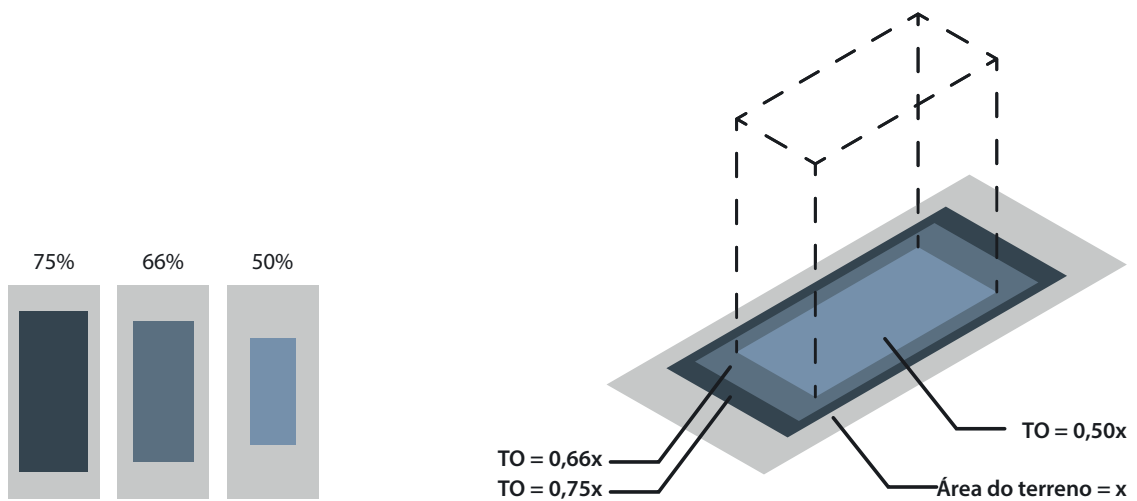

4.2.3. Índice de Aproveitamento

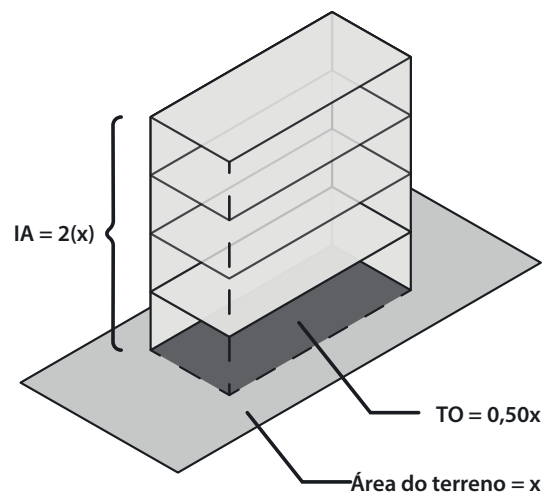

4.2.4. Recuos da Edificação

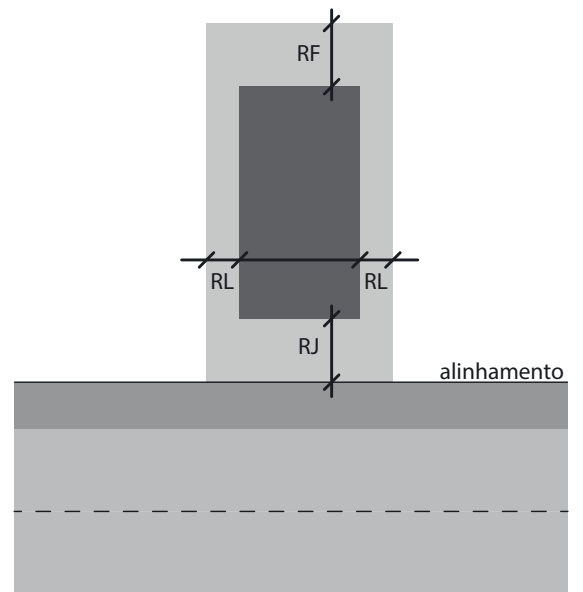

4.2.5. Tipologia Volume Simples nas divisas

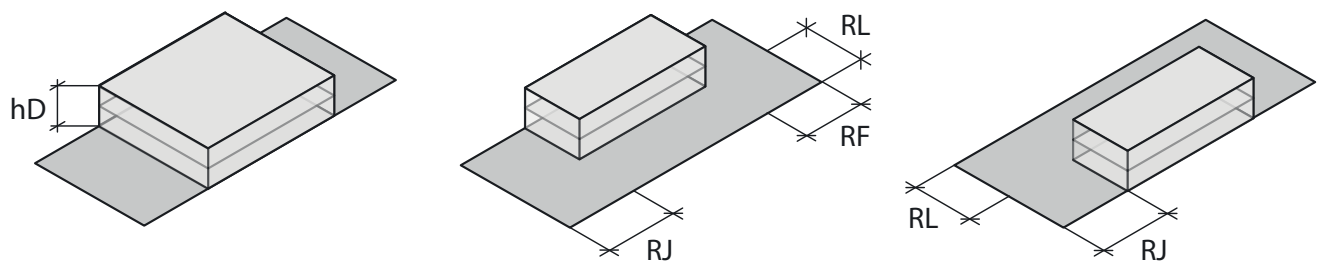

4.2.6. Tipologia Volume Simples Isolado

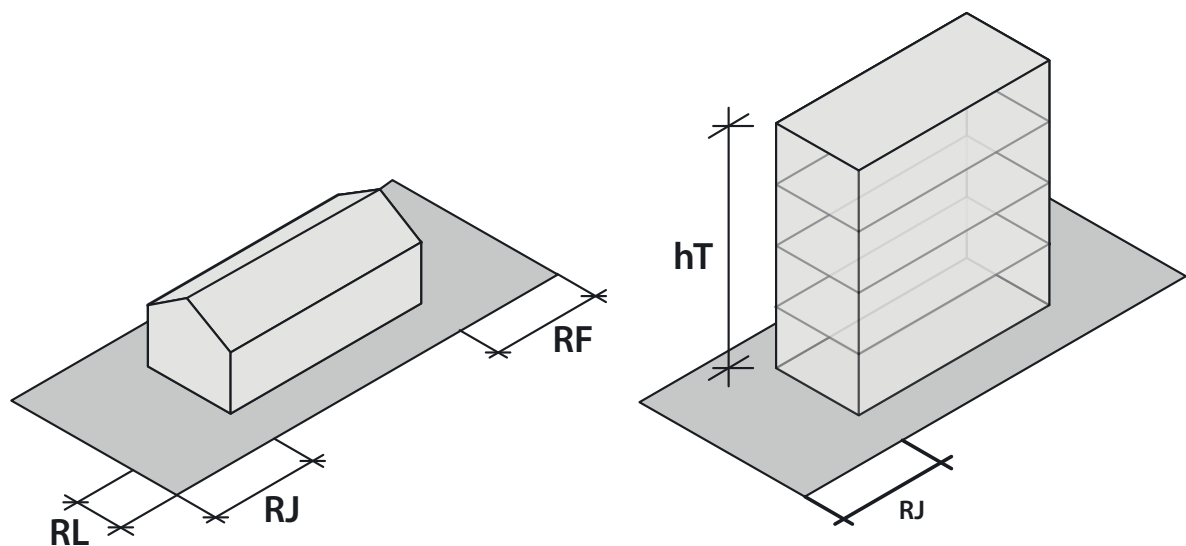

4.2.7. Volume Composto

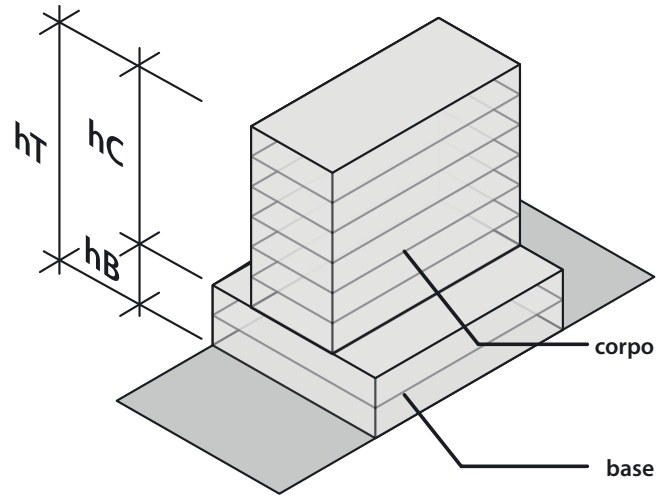

4.2.8. Referência de Nível

CORTE ESQUEMÁTICO

